

NEW ERRA DOORS

New Erra Doors Corp DBA Custom Door and Millworks

Florida Impact Approval:

FL #11436-R6

FBC VERSION: 2023

Certificate of Independence

Rule 61G20-3 F.A.C. | Report No. 2071-CI, Rev. 4 | Project No. 422-0604 | 6/12/23 | Page 1 of 1

Product Manufacturer

New Era Door Corp.
dba Custom Door and Millwork
2787 N. Airport Rd., Unit No. 410
Fort Myers, Florida 33907

Product Name, Model and/or Description

Impact Double Glazed Doors with Transom – Outswing and Inswing
Impact Double Opaque Entry Door – Outswing and Inswing

Code: Current Edition of the Florida Building Code including the 8th Edition (2023) Florida Building Code

Compliance Method: Product Approval Rule 61G20-3.009 – Certification of Independence

Certificate of Independence per Product Approval Rule 61G20-3.009

PTC Product Design Group, LLC and Robert J. Amoruso, P.E. does not have, nor will acquire, any financial interest in the company manufacturing or distributing product(s) covered by this Product Evaluation Report.

PTC Product Design Group, LLC and Robert J. Amoruso, P.E. do not have, nor will acquire any financial interest in any other entity involved in the approval process or testing of the product(s) covered by this Product Evaluation Report.

Robert J. Amoruso, P.E.
FL P.E. License Number 49752



Equivalency Evaluation Report

Rule 61G20-3 F.A.C. | Report No. 2071-EER, Rev. 4 | Project No. 422-0604 | 6/12/23 | Page 1 of 2

Product Manufacturer

New Era Door Corp.
dba Custom Door and Millwork
2787 N. Airport Rd., Unit No. 410
Fort Myers, Florida 33907

Product Name, Model and/or Description

Impact Double Glazed Doors with Transom – Outswing and Inswing
Impact Double Opaque Entry Door – Outswing and Inswing

Code: Current Edition of the Florida Building Code including the 8th Edition (2023) Florida Building Code

Compliance Methods: Product Approval Rule 61G20-3.015(5)(d) – Equivalency of Standards

- Impact Double Glazed Doors with Transom – Outswing and Inswing
 - CDM0003, Rev. E, dated 6/12/23 signed and sealed by Robert J. Amoruso, Custom Door and Millworks, Impact Double Glazed O.S. Door with Transom – Outswing and Inswing – Installation Anchorage Details
 - CTLA 1850W-1, dated September 09, 2008
- Impact Double Opaque Entry Door – Outswing and Inswing
 - CDM0004, Rev. E, dated 6/12/23, signed and sealed by Robert J. Amoruso, Custom Door and Millworks, Impact Double Opaque Entry Door – Outswing and Inswing – Installation Anchorage Details
 - CTLA 1850W, dated September 09, 2008

Performance Standards (used in testing):

- ASTM E330-02, Test Method for Structural Performance of Exterior Windows, Curtain Walls, and Doors by Uniform Static Air Pressure Difference.
- ASTM E547-00, Water Penetration of Exterior Windows and Doors by Static Air Pressure Difference.
- ASTM E283-04, Standard Test Method for Determining Rate of Air Leakage Through Exterior Windows, Curtain Walls, and Doors Under Specified Pressure Differences Across the Specimen
- ASTM E1886-05, Standard Test Method for Performance of Exterior Windows, Glazed Curtain Walls, Doors, and Storm Shutters Impacted by Missiles and Exposed to Cyclic Pressure Differentials.
- ASTM E1996-05, Standard Specification for Performance of Exterior Windows, Curtain Walls, Doors, and Storm Shutters Impacted by Windborne Debris in Hurricanes.

Equivalency Evaluation:

The following table shows the performance standards used in testing and those in the current edition of the FBC.

Standard Used in Testing		Current Edition of the Florida Building Code including the 8 th Edition (2023) Florida Building Code		Comments
Description	Revision Level	Building Volume (FBC)	Residential Volume (FRC)	
ASTM E330	02	14	14	See Evaluation Below
ASTM E547	00	Not in code	Not in code	
ASTM E283	04	04 (2012)	04 (2012)	
ASTM E1886	05	13a	13a	
ASTM E1996	05	14a	14a	

The AAMA and ASTM Standards listed above and used in testing have been compared to their current revision levels in the 8th Edition (2023) Florida Building Code and found to be acceptable. Changes in the current revisions do not affect the results obtained using previous versions of the reference standard.



Equivalency Evaluation Report

Rule 61G20-3 F.A.C. | Report No. 2071-EER, Rev. 4 | Project No. 422-0604 | 6/12/23 | Page 2 of 2

ASTM E1996 Testing Evaluation:

- 1) Wind Zone 4 testing
 - a. ASTM E1996-14 moved Wind Zone 4 criteria to the non-mandatory appendix. As indicated in Appendix X4.1, ASTM E1996-14a the Wind Zone 4 requirement, though non-mandatory, is still present and may be specified when needed to meet specific building codes requirements. Those requirements are detailed in Sections 1609.1.2.2, 1609.1.2.4 and 1609.3 of the Florida Building Code. Based on a review of the test reports, those parameters are met.
- 2) The Missile Level and Impact Speed used in testing are consistent with those currently required by the Florida Building Code and ASTM E11996.
- 3) The static load (ASTM E330) and cyclic load (ASTM E1886/E1996) parameters used in testing are consistent with those currently required by the Florida Building Code.

Certificate of Independence per Product Approval Rule 61G20-3.009

PTC Product Design Group, LLC and Robert J. Amoruso, P.E. does not have, nor will acquire, any financial interest in the company manufacturing or distributing product(s) covered by this Product Evaluation Report. PTC Product Design Group, LLC and Robert J. Amoruso, P.E. do not have, nor will acquire any financial interest in any other entity involved in the approval process or testing of the product(s) covered by this Product Evaluation Report.

Evaluated by:
Robert J. Amoruso, P.E.
FL PE License No. 49752



Product Evaluation Report

Rule 61G20-3 F.A.C. | Report No. 2071-PER, Rev. 4 | Project No. 422-0604 | 6/12/23 | Page 1 of 2

Product Manufacturer

New Era Door Corp.
dba Custom Door and Millwork
2787 N. Airport Rd., Unit No. 410
Fort Myers, Florida 33907

Product Name, Model and/or Description

Impact Double Glazed Door with Transom – Outswing and Inswing
Impact Double Opaque Entry Door – Outswing and Inswing

Code: Current Edition of the Florida Building Code including the 8th Edition (2023) Florida Building Code

Compliance Method: Product Approval Rule 61G20-3.005(1)(d) – Product Evaluation Report by a Licensed Professional Engineer

Product Name, Model and/or Designation; Test Report No.; and Installation Drawing No.:

- Impact Double Glazed Doors with Transom – Outswing and Inswing
 - CDM0003, Rev. E, dated 6/12/23 signed and sealed by Robert J. Amoruso, Custom Door and Millworks, Impact Double Glazed O.S. Door with Transom – Outswing and Inswing – Installation Anchorage Details
 - CTLA 1850W-1, dated September 09, 2008
- Impact Double Opaque Entry Door – Outswing and Inswing
 - CDM0004, Rev. E, dated 6/12/23, signed and sealed by Robert J. Amoruso, Custom Door and Millworks, Impact Double Opaque Entry Door – Outswing and Inswing – Installation Anchorage Details
 - CTLA 1850W, dated September 09, 2008

Component Approvals:

- Laminate Glass Interlayer: Uvekol Laminated Glass Interlayer by Allnex USA Inc. per current Miami-Dade Notice of Acceptance found [here](#).

Engineering Analysis & Evaluation:

- Anchorage engineering (Report No. 1133-Calc & 1119-Calc) in accordance with the current edition of the Florida Building Code, signed and sealed by Robert J. Amoruso, P.E., FL License Number 49752.
- Report No. 2568, Rev. 1, dated 6/12/23, signed and sealed by Robert J. Amoruso, P.E. FL No. 49752, Title: Product Evaluation of Door Lock Component Interchangeability to Custom Door & Millworks Wood Entry Doors
 - Von Duprin (Allegion) WS9827/9927 and/or WS9857/9957 Multi-Point exit device can be used as a replacement for the Emtek 8450 Cylinder Lock with single cylinder dead bolt & steel surface bolts with strike plates used in testing.
- Report No. 2597, Rev. 1, dated 6/12/23, signed and sealed by Robert J. Amoruso, P.E. FL No. 49752, Title: Product Evaluation of Custom Door & Millwork Inswing Wood Entry Doors
- Window glazing verified using ASTM E1300-12AE1 and ASTM E1300-2016

Performance Standards (used in testing):

- ASTM E330-02, Test Method for Structural Performance of Exterior Windows, Curtain Walls, and Doors by Uniform Static Air Pressure Difference.
- ASTM E547-00, Water Penetration of Exterior Windows and Doors by Static Air Pressure Difference.
- ASTM E283-04, Standard Test Method for Determining Rate of Air Leakage Through Exterior Windows, Curtain Walls, and Doors Under Specified Pressure Differences Across the Specimen
- ASTM E1886-05, Standard Test Method for Performance of Exterior Windows, Glazed Curtain Walls, Doors and Storm Shutters Impacted by Missiles and Exposed to Cyclic Pressure Differentials.
- ASTM E1996-05, Standard Specification for Performance of Exterior Windows, Curtain Walls, Doors and Storm Shutters Impacted by Windborne Debris in Hurricanes.



Product Evaluation Report

Rule 61G20-3 F.A.C. | Report No. 2071-PER, Rev. 4 | Project No. 422-0604 | 6/12/23 | Page 2 of 2

Limitations & Conditions of Use:

- The following product has been evaluated for outside the High Velocity Hurricane Zone (HVHZ).
 - Impact Double Glazed Doors with Transom – Outswing and Inswing
 - Impact Double Opaque Entry Door – Outswing and Inswing
- The following product will not require an approved impact protective system when used in wind borne debris regions including the HVHZ.
 - Impact Double Glazed Doors with Transom – Outswing and Inswing
 - Impact Double Opaque Entry Door – Outswing and Inswing
- Refer to Product Installation Instructions noted above for:
 - Maximum allowable wind loads at related maximum allowable size(s).
 - Overall dimensions and material/grade of main product components, accessories, etc.
 - Illustrated diagrams of the attachment of the product to substrate structure.
 - Anchor type(s), size(s), substrate(s), embedment, edge distance, and spacing/locations.
- Site wind pressures shall be determined by a licensed professional engineer in accordance with the current edition of the Florida Building Code (and/or ASCE 7 as referenced in the current edition of the Florida Building Code) for components and cladding based on allowable stress design.
- Site conditions not covered in this product evaluation document are subject to additional engineering analysis by a licensed professional engineer or registered architect as required by the authority having jurisdiction.
- Adequacy of the existing structural substrates as a main wind force resisting system capable of withstanding and transferring applied product loads to the foundation is the responsibility of the licensed professional engineer or registered architect acting as the design professional of record for the project of installation.

Certificate of Independence per Product Approval Rule 61G20-3.009

PTC Product Design Group, LLC and Robert J. Amoruso, P.E. does not have, nor will acquire, any financial interest in the company manufacturing or distributing product(s) covered by this Product Evaluation Report.

PTC Product Design Group, LLC and Robert J. Amoruso, P.E. do not have, nor will acquire any financial interest in any other entity involved in the approval process or testing of the product(s) covered by this Product Evaluation Report.

Evaluated By:
Robert J. Amoruso, P.E.
FL P.E. License Number 49752



CERTIFICATION OF PARTICIPATION

**National Accreditation and Management Institute, Inc.
confirms that:**

**New Erra Doors, LLC dba Custom Door and Millwork
2787 N. Airport Road #410
Fort Myers, Florida 33907**

**Participates within a Quality Assurance Program
that complies with ISO/IEC 17020 and Guide 53**

**New Erra Doors, LLC dba Custom Door and Millwork's
Quality Assurance ID # 1345-1**

**Quality Assurance Program for products
manufactured or assembled at referenced location.**



Thomas D. Wix, Quality Assurance Manager

Certificate Valid From 9/17/2024 to 12/31/2025

**The NAMI Program is recognized as an approved quality assurance entity
within the State of Florida # QUA1789.**

NOTICE OF PRODUCT CERTIFICATION



CERTIFICATION NO: NI009645-R10
DATE: 10/02/2008
CERTIFICATION PROGRAM: Structural
COMPANY: New Erra
CODE: 1345-1
REVISION DATE: 12/09/2024

This certification represents product conformity to the applicable specification and that certification criteria has been satisfied. A NAMI approved certification label must be applied to the product to claim certification status. To affirm the certification status, please visit www.namicertification.com. NAMI is accredited to the ISO/IEC 17065 by the Standards Council of Canada (SCC).

COMPANY NAME AND ADDRESS	PRODUCT DESCRIPTION
New Erra Doors, LLC dba Custom Door & Millworks 2787 N. Airport Road, #410 Fort Myers, FL 33907	“Mara Macho” Mahogany Out-Swing Double Opaque Entry Door One Active Panel/One Inactive Panel Configuration: XX Frame: W-7'3" H-10'2" Panel: W-3'6" H-10'0"

SPECIFICATION	PRODUCT RATING
ASTM E283-04/E330-02/E547-00 ASTM E1886-05/E1996-05	Design Pressure: +55/-55 psf Wind Zone 4 - Missile Level D

Product Tested By: Certified Testing Laboratories
Report No: CTLA-1850W
Expiration Date: September 30, 2025

Administrator's Signature: _____

NATIONAL ACCREDITATION AND MANAGEMENT INSTITUTE, INC.

4794 George Washington Memorial Highway
Hayes, VA 23072
Tel: (804) 684-5124

Email: nami@namiinc.com

NEW ERRA DOORS CORP, dba CUSTOM DOOR AND MILLWORK

IMPACT DOUBLE OPAQUE ENTRY DOOR

OUTSWING AND INSWING

INSTALLATION ANCHORAGE DETAILS

GENERAL NOTES:

1. THE PRODUCT SHOWN HEREIN IS DESIGNED TO COMPLY WITH THE CURRENT EDITION OF THE FLORIDA BUILDING CODE, BUILDING AND RESIDENTIAL VOLUMES EXCLUDING THE HIGH VELOCITY HURRICANE ZONE (HVHZ) AT THE DESIGN PRESSURES STATED HEREIN.
2. THE PRODUCT DETAILS CONTAINED HEREIN ARE BASED UPON SIGNED AND SEALED TEST REPORT(S) NO. CTLA 1850W AND ASSOCIATED LABORATORY DRAWINGS.
3. ADEQUACY OF THE EXISTING STRUCTURAL CONCRETE / MASONRY AND 2X FRAMING AS A MAIN WIND FORCE RESISTING SYSTEM CAPABLE OF WITHSTANDING AND TRANSFERRING APPLIED PRODUCT LOADS TO THE STRUCTURE IS THE RESPONSIBILITY OF THE ENGINEER OR ARCHITECT OF RECORD.
4. 1X AND 2X BUCKS (WHEN USED) SHALL BE DESIGNED AND ANCHORED TO PROPERLY TRANSFER ALL LOADS TO THE STRUCTURE. BUCK DESIGN AND INSTALLATION IS THE RESPONSIBILITY OF THE ENGINEER OR ARCHITECT OF RECORD.
5. THIS PRODUCT DOES NOT REQUIRE AN IMPACT PROTECTIVE SYSTEM THAT COMPLIES WITH THE CURRENT EDITION OF THE FLORIDA BUILDING CODE, BUILDING AND RESIDENTIAL VOLUMES IN THE WIND BORNE DEBRIS REGION. THE PRODUCT IS IMPACT-RESISTANT TO WIND ZONE 4, MISSILE LEVEL D.
6. DOOR FRAME AND PANEL MATERIAL: MAHOGANY.
7. DESIGNATION "X" STANDS FOR OPERABLE PANEL - SEE ELEVATION ON SHEET 2.
8. HARDWARE TESTED:
 - 9.1 EMTEK 8450 CYLINDER LOCK WITH SINGLE CYLINDER DEAD BOLT.
 - 9.2 STEEL SURFACE BOLTS WITH STRIKE PLATES. TWO HANDLE STYLES SHOWN FOR OUTSWING VS. INSWING. OTHER STYLES ACCEPTABLE.

INSTALLATION NOTES:

1. ONE (1) INSTALLATION ANCHOR IS REQUIRED AT EACH ANCHOR LOCATION SHOWN.
2. THE INSTALLATION ANCHOR SPACING DEPICTED DICTATES THE MINIMUM NUMBER OF ANCHORS TO BE USED FOR PRODUCT INSTALLATION. ANCHORS ARE TO MATCH TYPE, SIZE, AND EMBEDMENT OF THOSE SHOWN HEREIN FOR RESPECTIVE SUBSTRATE.
3. SHIM AS REQUIRED AT EACH INSTALLATION ANCHOR WITH LOAD BEARING SHIM(S). MAXIMUM ALLOWABLE SHIM SIZE IS 1/4 INCH. SHIM WHERE SPACE OF 1/16 INCH OR GREATER OCCURS. SHIM(S) SHALL BE CONSTRUCTED OF HIGH DENSITY PLASTIC OR BETTER.
4. FOR INSTALLATION INTO WOOD FRAMING, USE #12 WOOD SCREWS OF SUFFICIENT LENGTH TO ACHIEVE 1 1/2 INCH MINIMUM EMBEDMENT. MINIMUM EDGE DISTANCE SHALL BE 7/8 INCH TO EDGE OF SUPPORTING WOOD SUBSTRATE.
5. FOR INSTALLATION THROUGH 1X BUCK TO CONCRETE / MASONRY, OR DIRECTLY INTO CONCRETE / MASONRY, USE 3/16 INCH ITW TAPCONS (ADVANCED THREADFORM TYPE) OF SUFFICIENT LENGTH TO ACHIEVE 1 1/2 INCH MINIMUM EMBEDMENT INTO CONCRETE AND 1 INCH MINIMUM EMBEDMENT INTO MASONRY (CMU). MINIMUM EDGE DISTANCES SHALL BE 1-1/8 INCH IN CONCRETE AND 2 INCHES INTO MASONRY (CMU).
6. ALTERNATE CONCRETE / MASONRY / WOOD INSTALLATION ANCHORS OF EQUIVALENT PERFORMANCE CHARACTERISTICS CAN BE USED UPON APPROVAL BY THE ARCHITECT OR ENGINEER OF RECORD.
7. MINIMUM EMBEDMENT AND EDGE DISTANCE EXCLUDE WALL FINISHES (INCLUDING BUT NOT LIMITED TO STUCCO, FOAM, BRICK VENEER, AND SIDING).
8. INSTALLATION ANCHORS AND ASSOCIATED HARDWARE MUST BE MADE OF CORROSION RESISTANT MATERIAL OR HAVE A CORROSION RESISTANT COATING DISSIMILAR METALS OR MATERIALS IN CONTACT WITH PRESSURE TREATED WOOD MUST BE PROTECTED TO PREVENT REACTION.
9. FOR HOLLOW BLOCK AND GROUT FILLED BLOCK, DO NOT INSTALL INSTALLATION ANCHORS INTO MORTAR JOINTS. EDGE DISTANCE IS MEASURED FROM FREE EDGE OF BLOCK OR EDGE OF MORTAR JOINT INTO FACE SHELL OF BLOCK.
10. INSTALLATION ANCHORS SHALL BE INSTALLED IN ACCORDANCE WITH ANCHOR MANUFACTURER'S INSTALLATION INSTRUCTIONS AND ANCHORS SHALL NOT BE USED IN SUBSTRATES WITH STRENGTHS LESS THAN THE MINIMUM STRENGTH SPECIFIED BY THE ANCHOR MANUFACTURER AND/OR AS REQUIRED BELOW IN NOTE 11.
11. INSTALLATION ANCHOR CAPACITIES FOR PRODUCTS HEREIN ARE BASED ON SUBSTRATE MATERIALS WITH THE FOLLOWING PROPERTIES:
 - 11.1. WOOD - MINIMUM SPECIFIC GRAVITY OF 0.42.
 - 11.2. CONCRETE - MINIMUM COMPRESSIVE STRENGTH OF 2500 psi
 - 11.3. MASONRY - STRENGTH CONFORMANCE TO ASTM C-90, MEDIUM WEIGHT WITH DENSITY > 117 PCF.

PERFORMANCE RATING			
CONFIGURATION	DESIGN PRESSURE RATING	IMPACT RATING	WATER PENTRATION RATING
OUTSWING	+/-55 PSF	WIND ZONE 4 MISSILE LEVEL D	YES (Note 1)
INSWING	+/-55 PSF	WIND ZONE 4 MISSILE LEVEL D	NONE (Note 2)

WATER PENETRATION TESTING NOTES

1) OUTSWING CONFIGURATION TESTED FOR WATER PENETRATION IN ACCORDANCE WITH ASTM E547. THEREFORE, INSTALLATION APPROVED FOR ALL LOCATIONS WHERE WATER PENETRATION RESISTANCE IS REQUIRED.

2) INSWING CONFIGURATION NOT TESTED FOR WATER PENETRATION IN ACCORDANCE WITH ASTM E547. THEREFORE, INSTALLATION APPROVED ONLY FOR LOCATIONS WHERE WATER PENETRATION RESISTANCE IS NOT REQUIRED OR WHERE A OVERHANG MEETING THE REQUIREMENTS OF THE FBC HAVE BEEN MET. SEE BELOW FOR OVERHANG REQUIREMENTS..

In accordance with 8th Edition (2023) Florida Building Code Section 1709.5.2, Exception 1 & 2 & 8th Edition (2023) Florida Residential Code Section R609.3, Exception 1 & 2.
 Door assemblies may be installed where the overhang (OH) ratio is equal to or more than 1 need not be tested for water infiltration. The overhang ratio shall be calculated by the following equation:
 OH ratio = OH Length/OH Height
 where:
 OH Length = The horizontal measure of how far an overhang over a door projects out from the door's surface.
 OH Height = The vertical measure of the distance from the door's sill to the bottom of the overhang over a door.

DRAWING SHEET INDEX	
SHEET	DESCRIPTION
1	GENERAL AND INSTALLATION NOTES
2	ELEVATION AND ANCHOR LAYOUT
3	ADDITIONAL APPROVED CONFIGURATIONS
4	OUTSWING INSTALLATION - VERTICAL SECTIONS
5	INSWING INSTALLATION - VERTICAL SECTIONS
6	OUTSWING INSTALLATION - HORIZONTAL SECTIONS
7	INSWING INSTALLATION - HORIZONTAL SECTIONS

PROJECT #422-0604							
NEW ERRA DOORS CORP, dba CUSTOM DOOR & MILLWORK 2787 N. AIRPORT RD., UNIT NO. 410 FORT MYERS, FLORIDA 33907	TITLE: IMPACT DOUBLE OPAQUE ENTRY DOOR, O/S & I/S GENERAL AND INSTALLATION NOTES	DRAWN BY: BB	DATE: 09/25/08	UPDATE TO 8TH EDITION (2023) FBC	RJA	6/12/23	
	PREPARED BY: N.T.S.	SCALE: N.T.S.	DRAWING NO: CDM0004	UPDATE TO 7TH EDITION (2020) FBC	RJA	01/24/21	
	REV: E	SHEET: 1 OF 7	DESCRIPTION	REV	DATE	BY	

Robert J. Amoruso, P.E.
FL P.E. No. 49752

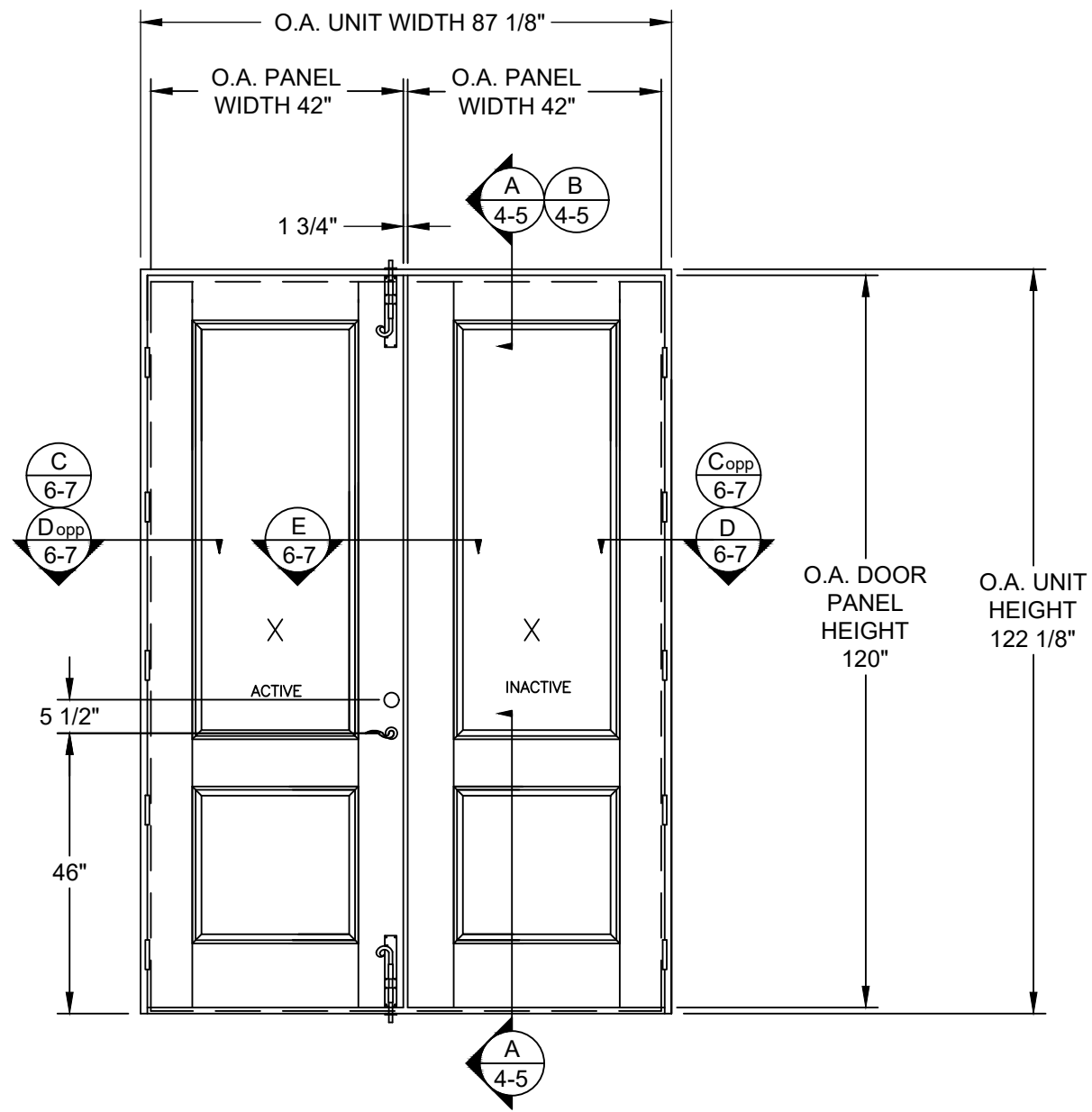

ELEVATION
DOUBLE ENTRY DOOR
INERIOR VIEW

OUTSWING ELEVATION SHOWN
INSWING SIMILAR

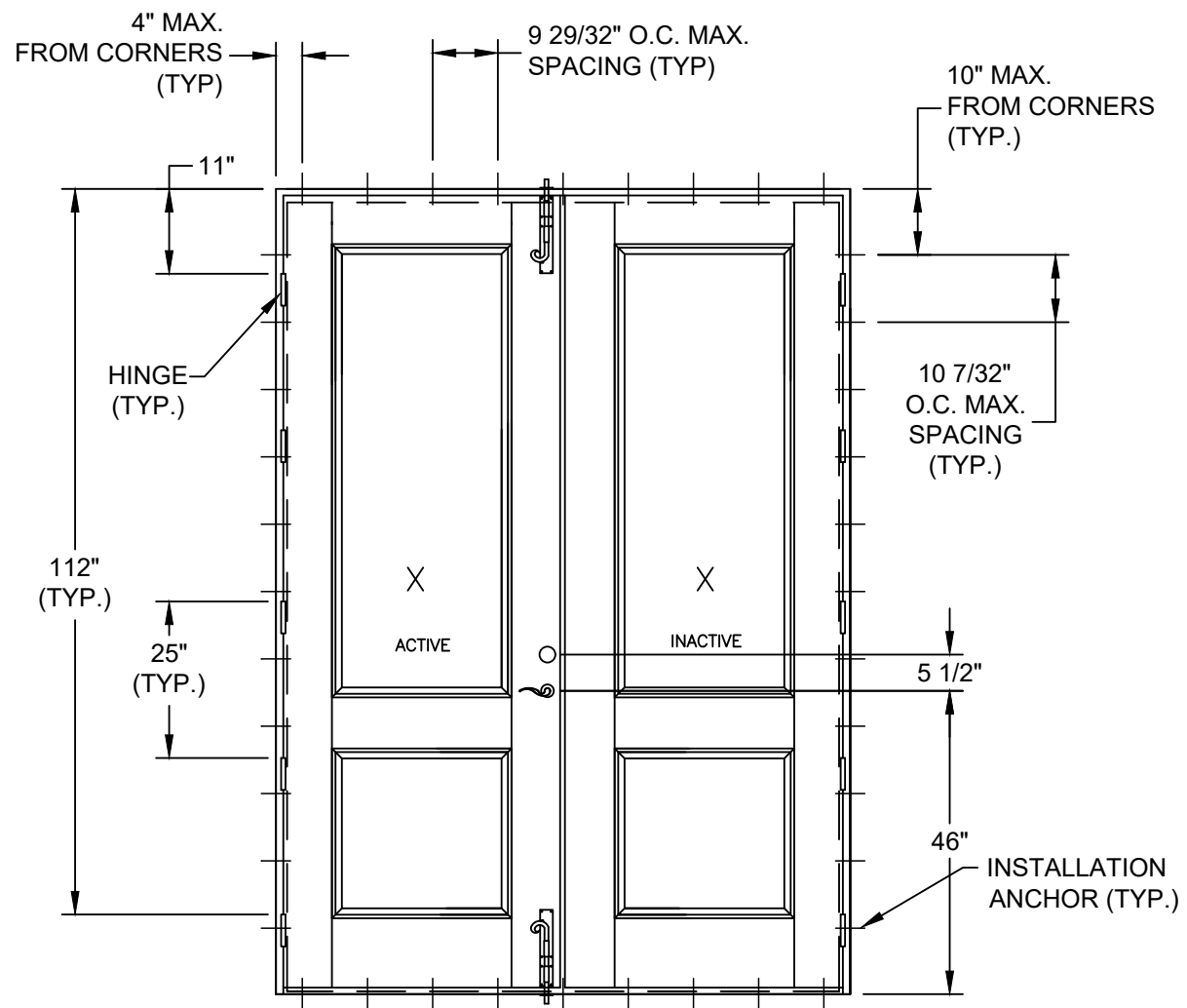

ANCHOR LAYOUT
DOUBLE ENTRY DOOR
INTERIOR VIEW

NEW ERRA DOORS CORP, dba CUSTOM DOOR & MILLWORK
2787 N. AIRPORT RD., UNIT NO. 410
FORT MYERS, FLORIDA 33907

TITLE: IMPACT DOUBLE OPAQUE ENTRY DOOR, O/S & I/S
ELEVATION & ANCHOR LAYOUT

PREPARED BY:	BB	DATE:	09/25/08
DRAWN BY:	BB	DRAWING NO.:	CDM0004
SCALE:	N.T.S.	SHEET:	2 OF 7
REV:	E	REV:	

Robert J. Amoruso, P.E.
FL P.E. No. 49752

PROJECT #422-0604

REV	DESCRIPTION	DATE	BY
E	UPDATE TO 8TH EDITION (2023) FBC	6/12/23	RJA
D	UPDATE TO 7TH EDITION (2020) FBC	01/24/21	RJA

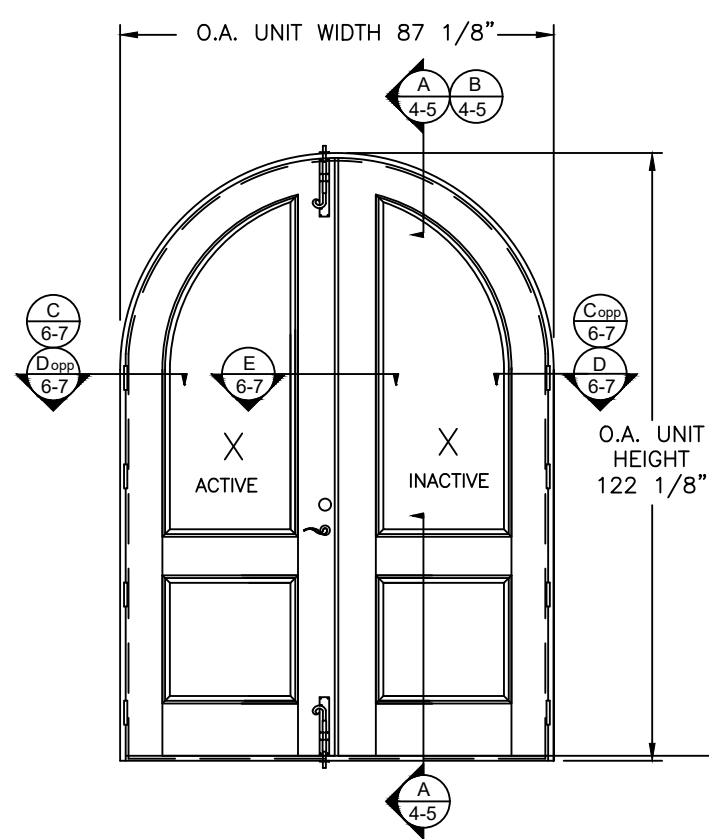

ELEVATION
DOUBLE ARCH TOP ENTRY DOORS
INTERIOR VIEW

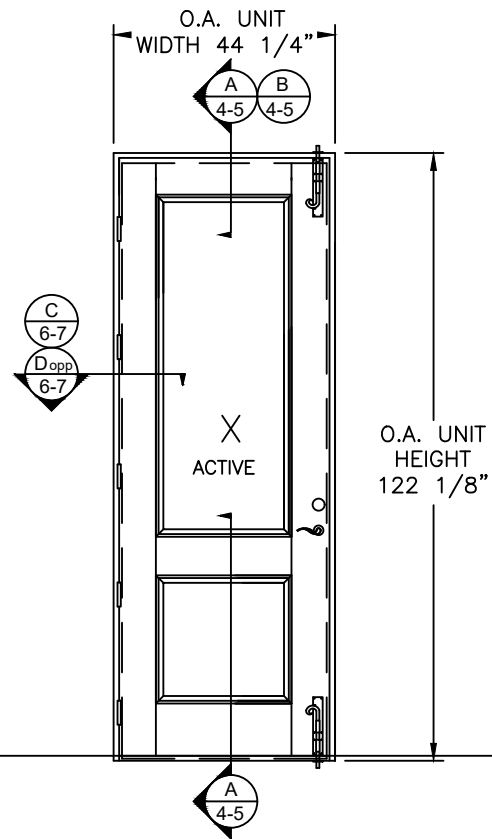

ELEVATION
SINGLE ENTRY DOOR
INTERIOR VIEW

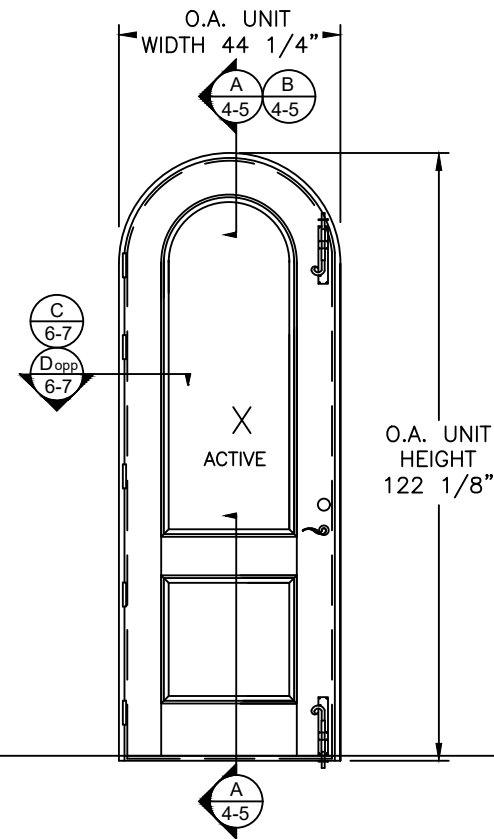

ELEVATION
SINGLE ARCH TOP ENTRY DOOR
INTERIOR VIEW

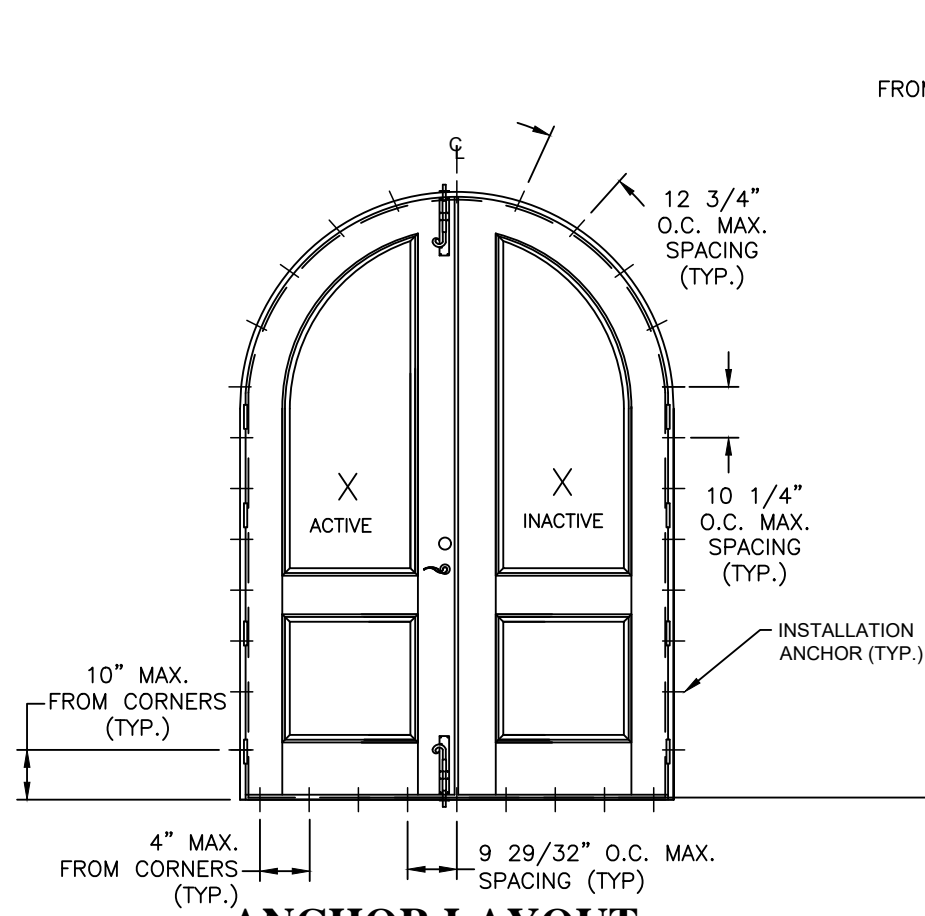

ANCHOR LAYOUT
DOUBLE ARCH TOP ENTRY DOORS
INTERIOR VIEW

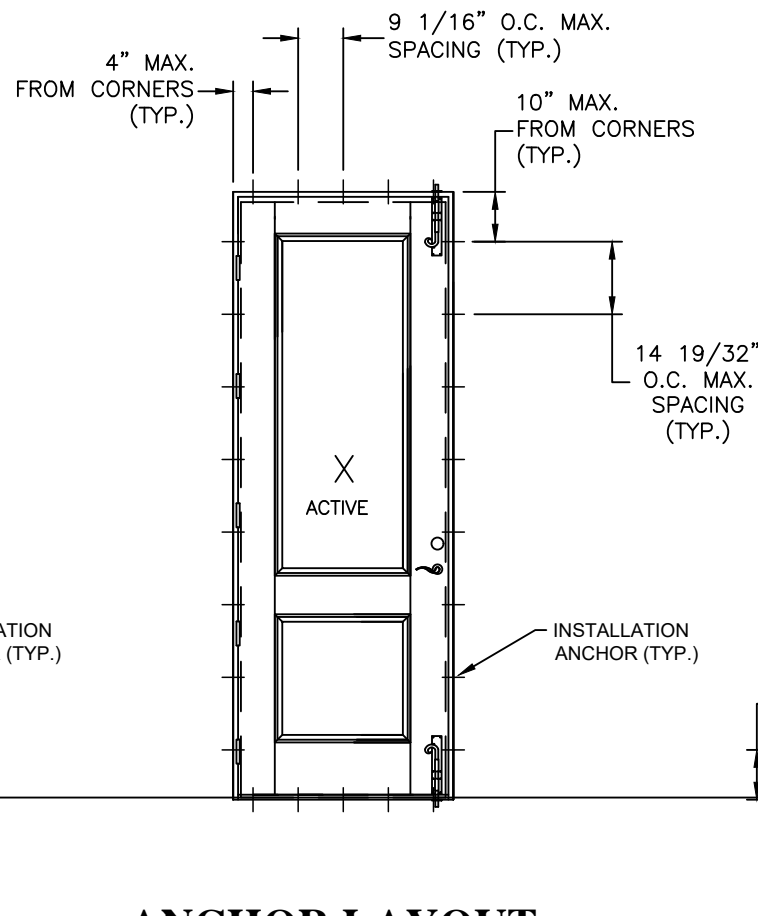

ANCHOR LAYOUT
SINGLE ENTRY DOOR
INTERIOR VIEW

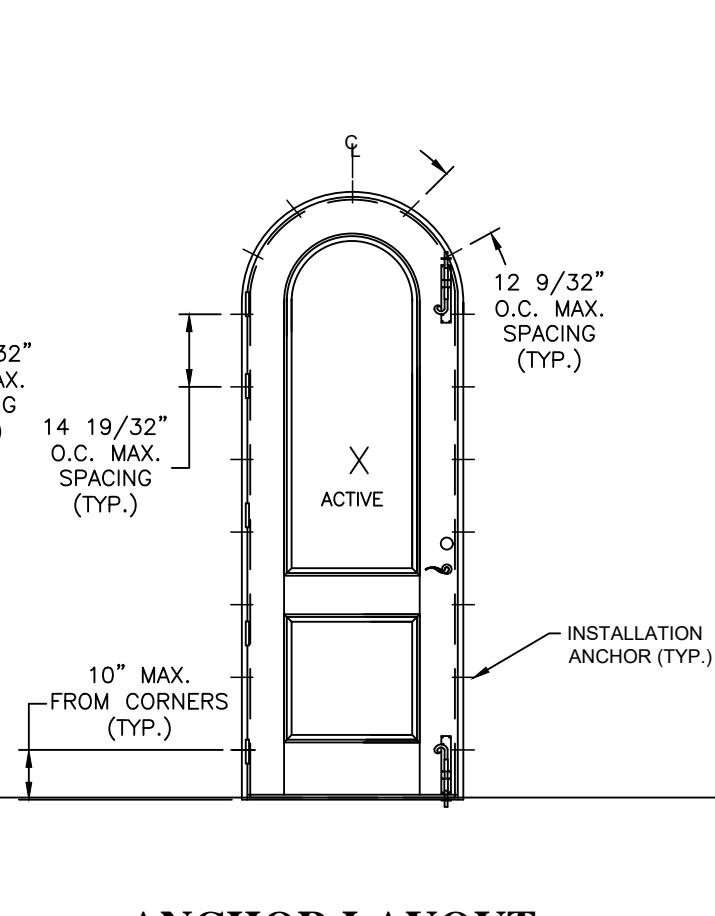

ANCHOR LAYOUT
INTERIOR VIEW

PROJECT #422-0604

NEW ERRA DOORS CORP, dba CUSTOM DOOR & MILLWORK
2787 N. AIRPORT RD., UNIT NO. 410
FORT MYERS, FLORIDA 33907

TITLE: IMPACT DOUBLE OPAQUE ENTRY DOOR, O/S & I/S
ADDITIONAL APPROVED CONFIGURATIONS

PREPARED BY: BB
DATE: 09/25/08
DRAWING NO.: CDM0004

SCALE: N.T.S.
SHEET: 3 OF 7

REV: E

DESCRIPTION: DATE: BY: RJA

Robert J. Amoruso, P.E.
FL P.E. No. 49752



PTC PRODUCT DESIGN GROUP, LLC
PO BOX 520775
LONG BEACH, CA 90802
Phone: 321.690.1788
Fax: 321.690.1789
Email: info@pdc-corp.com

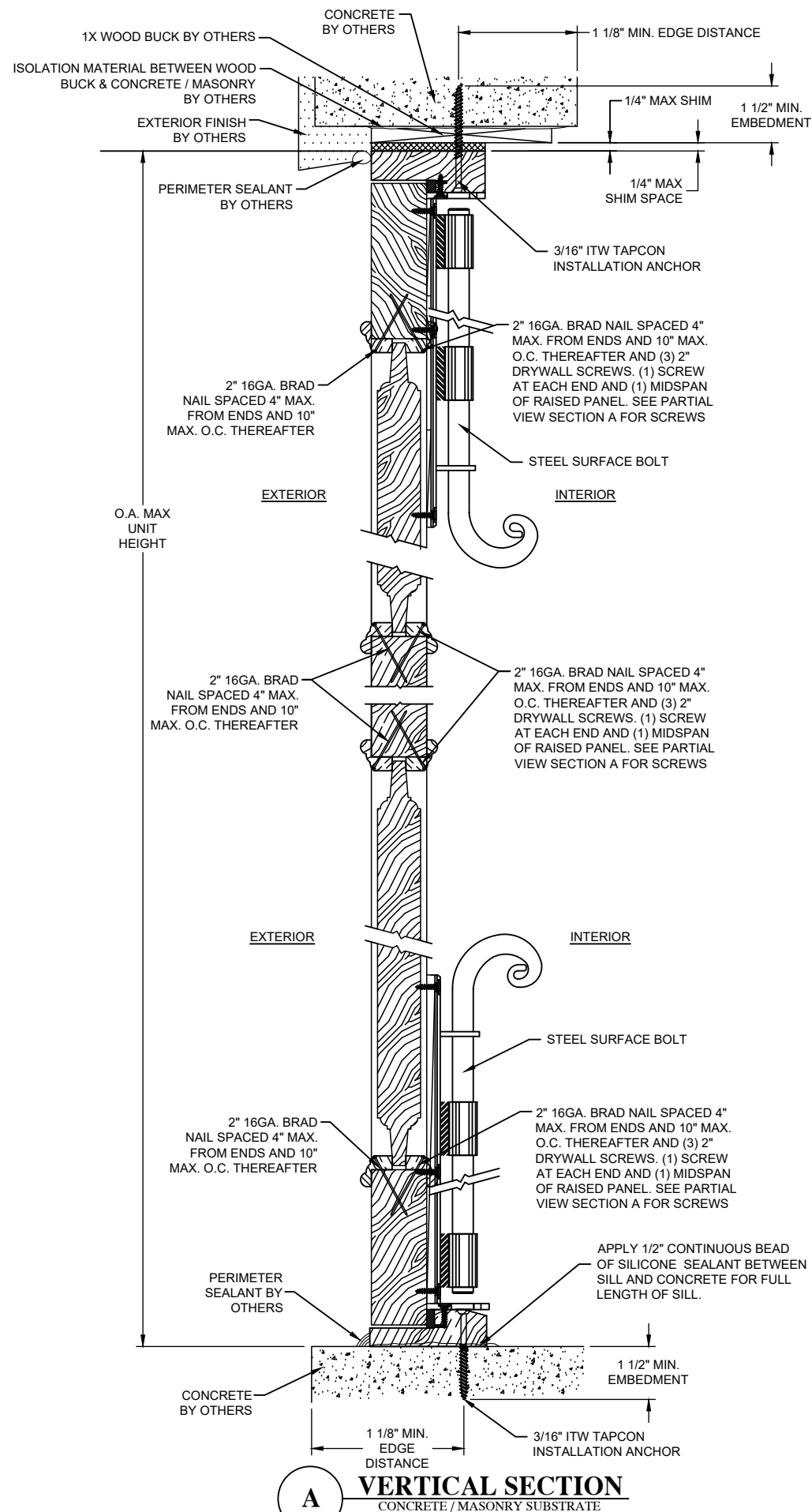

A VERTICAL SECTION
CONCRETE / MASONRY SUBSTRATE

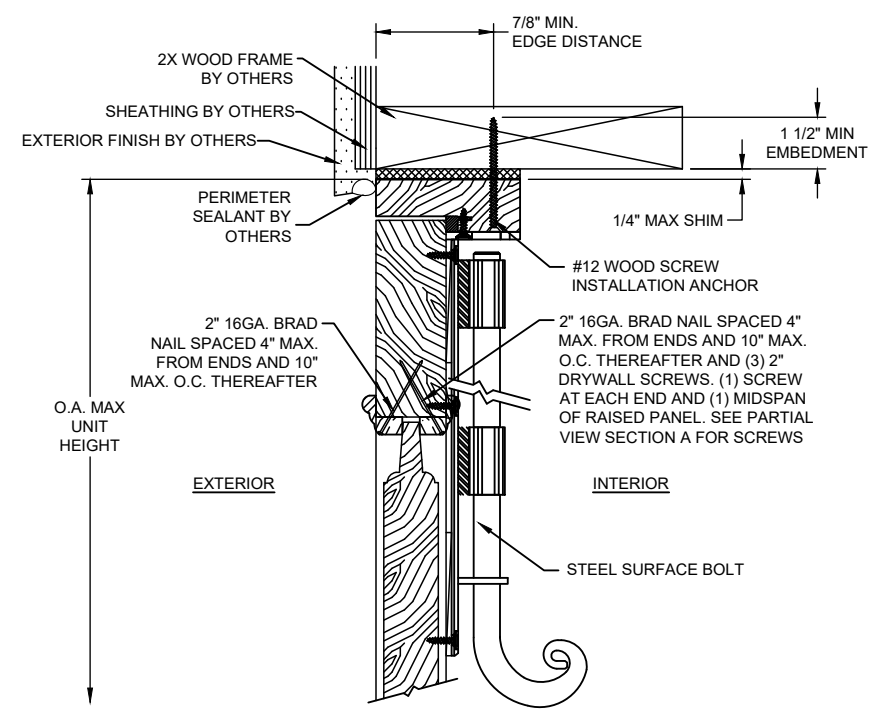

B VERTICAL SECTION
2X WOOD SUBSTRATE

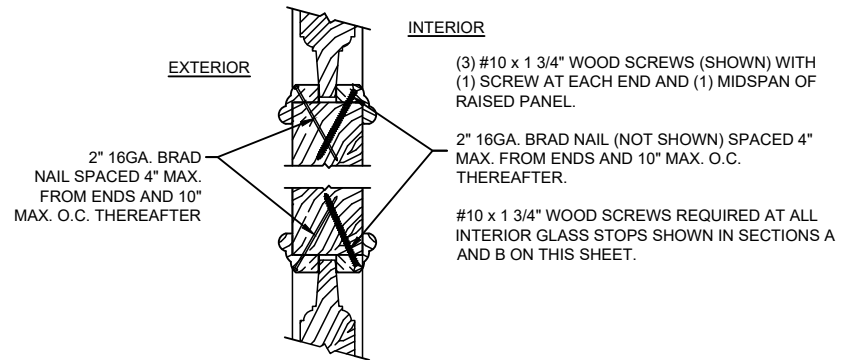

A PARTIAL VIEW
VERTICAL SECTION

**OUTSWING INSTALLATION
VERTICAL SECTION VIEWS**

PROJECT #422-0604		DATE	BY
UPDATE TO 8TH EDITION (2023) FBC	6/12/23	RJA	RJA
UPDATE TO 7TH EDITION (2020) FBC	01/24/21	RJA	RJA
DESCRIPTION	REV	DATE	BY
IMPACT DOUBLE OPAQUE ENTRY DOOR, O/S & I/S OUTSWING INSTALLATION - VERTICAL SECTIONS	E	09/25/08	BB
	D		N.T.S.
	REV		CDM0004
			SHEET: 4 OF 7

NEW ERRA DOORS CORP, dba CUSTOM DOOR & MILLWORK
2787 N. AIRPORT RD., UNIT NO. 410
FORT MYERS, FLORIDA 33907

PREPARED BY: BB
SCALE: N.T.S.
DATE: 09/25/08
DRAWING NO.: CDM0004
SHEET: 4 OF 7

PTC PRODUCT DESIGN GROUP, LLC
PO BOX 520775
LONGWOOD, FLORIDA 32752
FBPE CA. NO. 25835
Phone: 321.690.1788
Fax: 321.690.1789
Email: info@ptc-corp.com

Robert J. Amoruso, P.E.
FL P.E. No. 49752

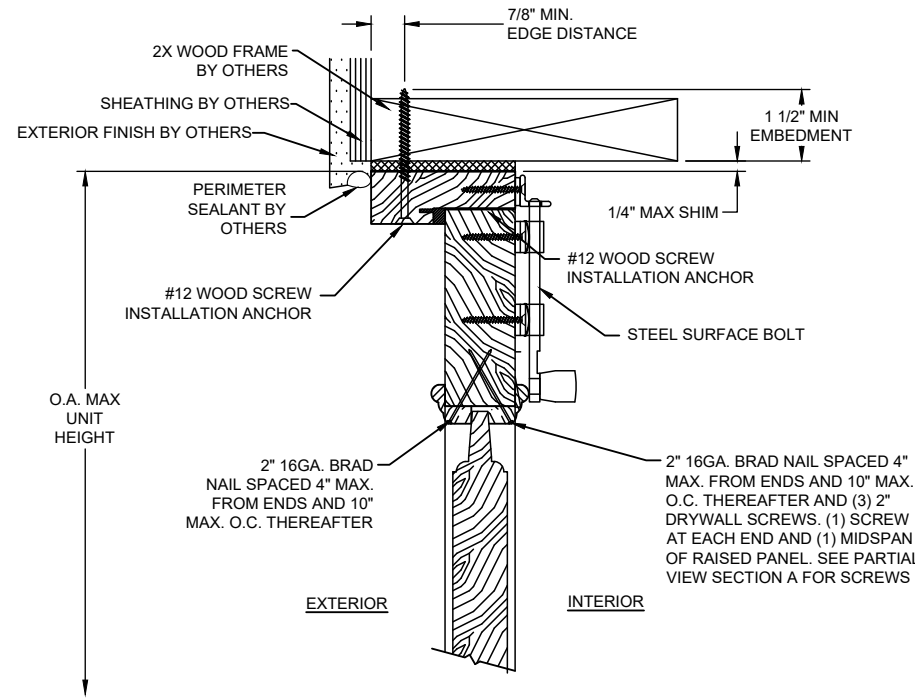
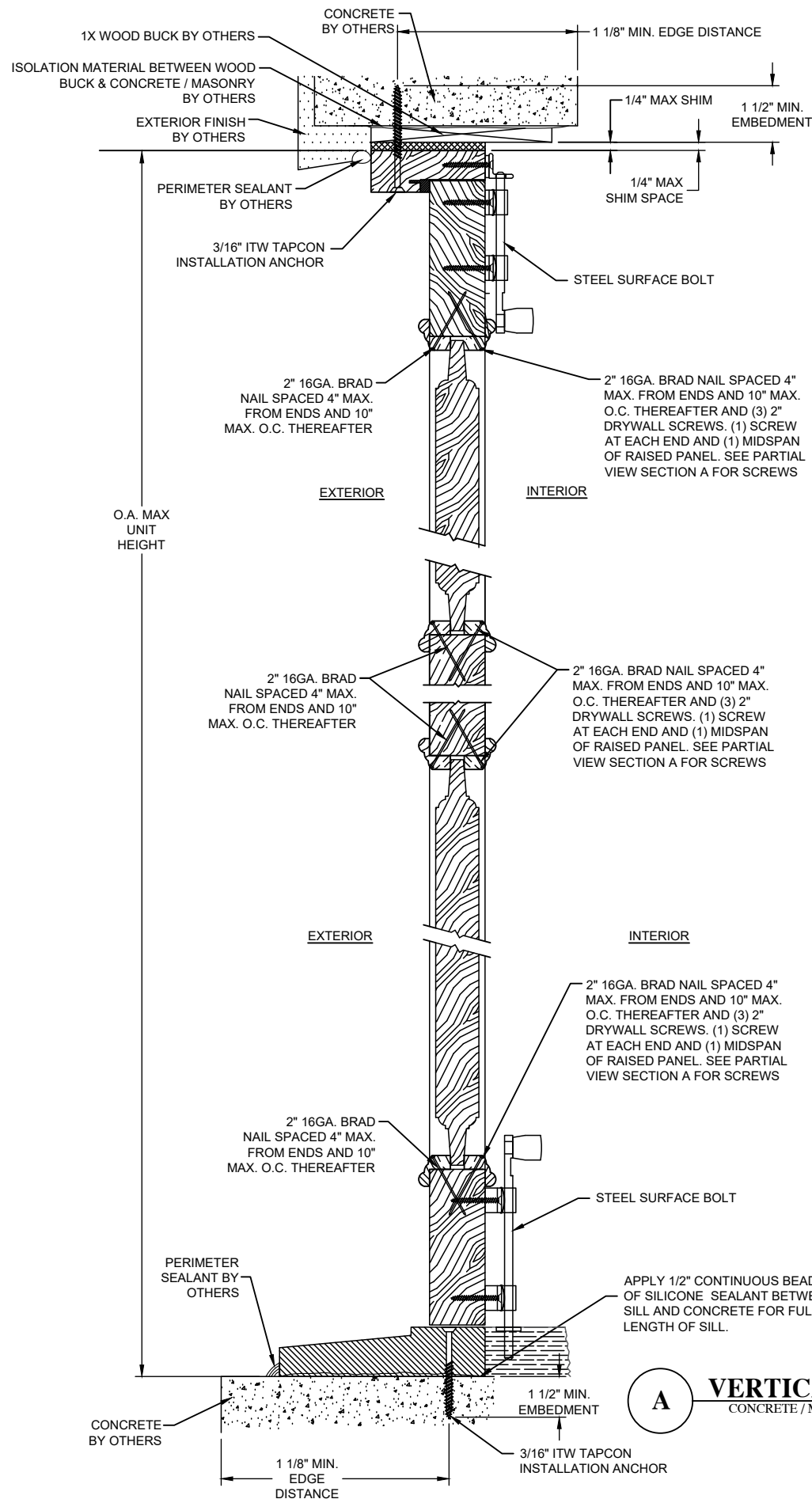

B VERTICAL SECTION
2X WOOD SUBSTRATE

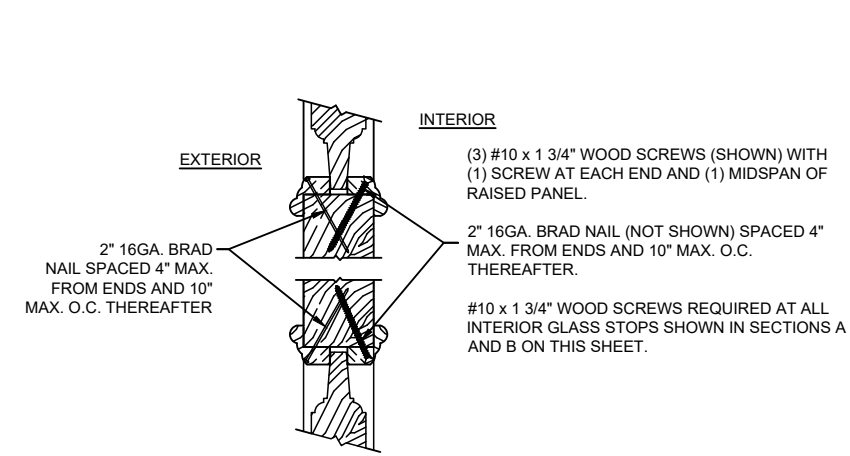

**INSWING INSTALLATION
VERTICAL SECTION VIEWS**

A VERTICAL SECTION
CONCRETE / MASONRY SUBSTRATE

PROJECT #422-0604

		RJA	BY
		6/12/23	DATE
E	UPDATE TO 8TH EDITION (2023) FBC		DESCRIPTION
D	UPDATE TO 7TH EDITION (2020) FBC		DESCRIPTION
REV			DATE

NEW ERRA DOORS CORP, dba CUSTOM DOOR & MILLWORK
2787 N. AIRPORT RD., UNIT NO. 410
FORT MYERS, FLORIDA 33907

TITLE: IMPACT DOUBLE OPAQUE ENTRY DOOR, O/S & I/S
INSWING INSTALLATION - VERTICAL SECTIONS

PREPARED BY: BB
SCALE: N.T.S.
DATE: 09/25/08
DRAWING NO.: CDM0004
SHEET: 5 OF 7

PTC PRODUCT DESIGN GROUP, LLC
PO BOX 520775
LONGWOOD, FLORIDA 32752
Phone: 321.690.1788
Fax: 321.690.1789
Email: info@ptc-corp.com

Robert J. Amoruso, P.E.
FL P.E. No. 49752

OUTSWING INSTALLATION HORIZONTAL SECTION VIEWS

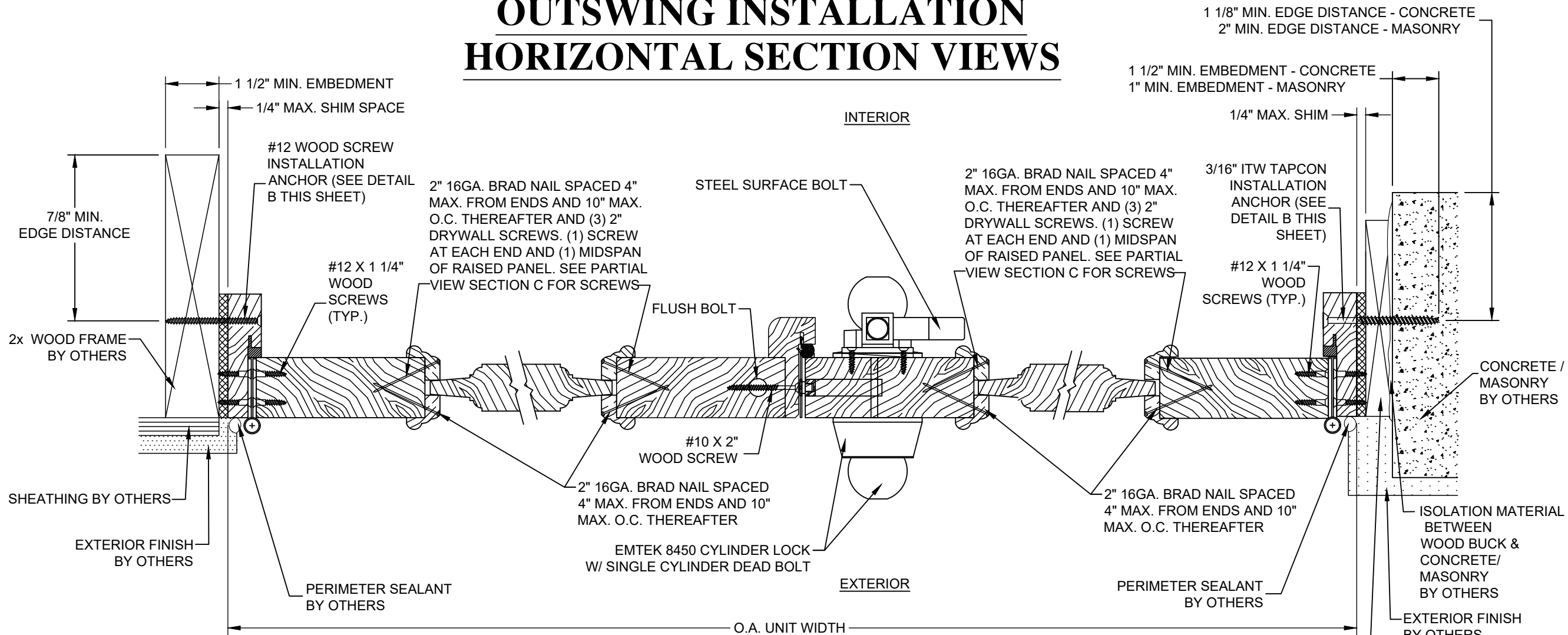

C HORIZONTAL SECTION
2X WOOD SUBSTRATE

E HORIZONTAL SECTION
ASTRAGAL

D HORIZONTAL SECTION
CONCRETE / MASONRY SUBSTRATE

(3) #10 x 1 3/4" WOOD SCREWS (SHOWN) WITH (1) SCREW AT EACH END AND (1) MIDSPAN OF RAISED PANEL.

2" 16GA. BRAD NAIL (NOT SHOWN) SPACED 4" MAX. FROM ENDS AND 10" MAX. O.C. THEREAFTER.

#10 x 1 3/4" WOOD SCREWS REQUIRED AT ALL INTERIOR GLASS STOPS SHOWN IN SECTIONS C AND D ON THIS SHEET.

2" 16GA. BRAD NAIL SPACED 4" MAX. FROM ENDS AND 10" MAX. O.C. THEREAFTER

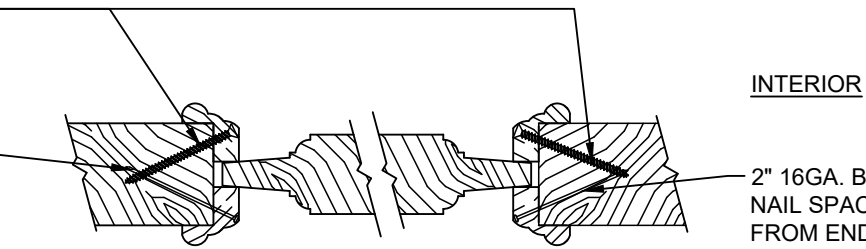

C PARTIAL VIEW HORIZONTAL SECTION

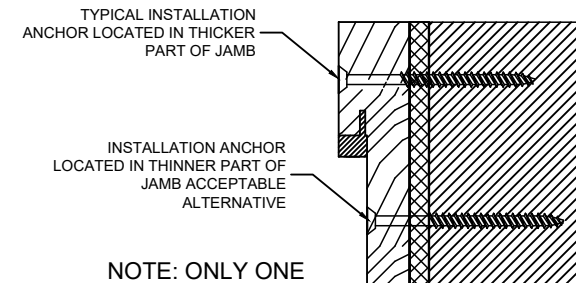

NOTE: ONLY ONE INSTALLATION ANCHOR REQUIRED, EITHER IN THICKER OR THINNER PART OF JAMB; NOT BOTH.

DETAIL B
INSTALLATION ANCHOR LOCATION ALTERNATIVES

PROJECT #422-0604

NEW ERRA DOORS CORP, dba CUSTOM DOOR & MILLWORK
2787 N. AIRPORT RD., UNIT NO. 410
FORT MYERS, FLORIDA 33907

TITLE: IMPACT DOUBLE OPAQUE ENTRY DOOR, O/S & I/S
OUTSWING INSTALLATION - HORIZONTAL SECTIONS

PREPARED BY:	DATE:	DRAWING NO.:	SHEET:
BB	09/25/08	CDM0004	6 OF 7
SCALE:	N.T.S.	REV:	E
REV:	E	DESCRIPTION	DATE
			BY
			RJA
			6/12/23
			RJA
			01/24/21
			DATE
			BY

Robert J. Amoruso, P.E.
FL P.E. No. 49752

PTC PRODUCT DESIGN GROUP, LLC
PO BOX 520775
LONGWOOD, FLORIDA 32752
FBPE C.A. NO. 25935
Phone: 321.690.1788
Fax: 321.690.1789
Email: info@ptc-corp.com

INSWING INSTALLATION HORIZONTAL SECTION VIEWS

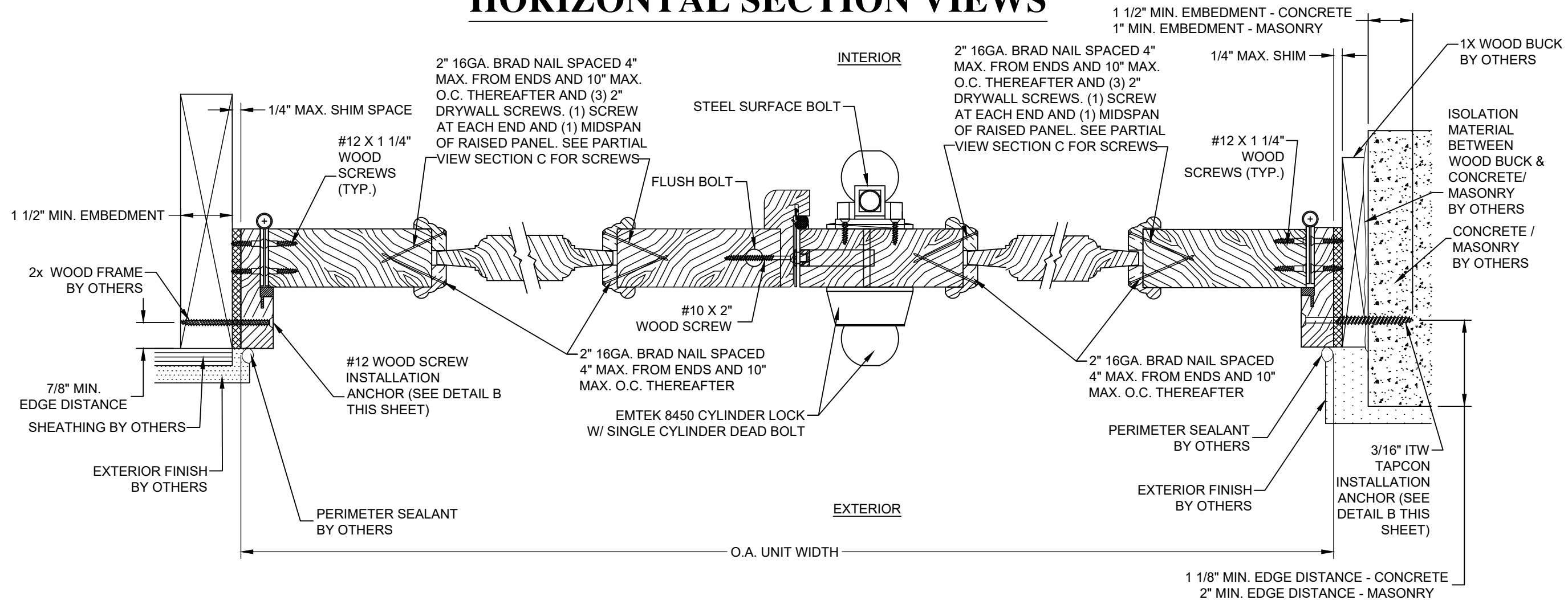

C HORIZONTAL SECTION
2X WOOD SUBSTRATE

E HORIZONTAL SECTION
ASTRAGAL

D HORIZONTAL SECTION
CONCRETE / MASONRY SUBSTRATE

(3) #10 x 1 3/4" WOOD SCREWS (SHOWN) WITH (1) SCREW AT EACH END AND (1) MIDSPAN OF RAISED PANEL.

2" 16GA. BRAD NAIL (NOT SHOWN) SPACED 4" MAX. FROM ENDS AND 10" MAX. O.C. THEREAFTER.

#10 x 1 3/4" WOOD SCREWS REQUIRED AT ALL INTERIOR GLASS STOPS SHOWN IN SECTIONS C AND D ON THIS SHEET.

2" 16GA. BRAD NAIL SPACED 4" MAX. FROM ENDS AND 10" MAX. O.C. THEREAFTER

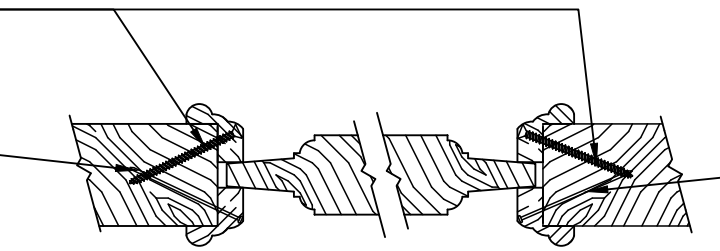

C PARTIAL VIEW HORIZONTAL SECTION

INTERIOR

EXTERIOR

2" 16GA. BRAD NAIL SPACED 4" MAX. FROM ENDS AND 10" MAX. O.C. THEREAFTER

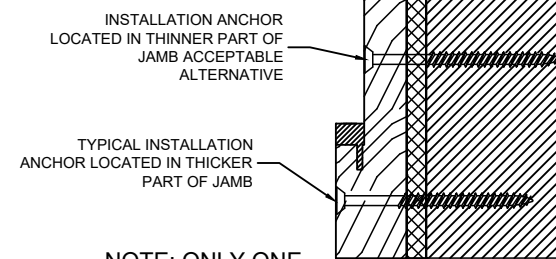

NOTE: ONLY ONE INSTALLATION ANCHOR REQUIRED, EITHER IN THICKER OR THINNER PART OF JAMB; NOT BOTH.

DETAIL B
INSTALLATION ANCHOR LOCATION ALTERNATIVES

PROJECT #422-0604

NEW ERRA DOORS CORP, dba CUSTOM DOOR & MILLWORK
2787 N. AIRPORT RD., UNIT NO. 410
FORT MYERS, FLORIDA 33907

TITLE: IMPACT DOUBLE OPAQUE ENTRY DOOR, O/S & I/S
INSWING INSTALLATION - HORIZONTAL SECTIONS

PREPARED BY: BB
SCALE: N.T.S.
REV: E

DATE: 09/25/08
DRAWING NO: CDM0004
SHEET: 7 OF 7



Robert J. Amoruso, P.E.
FL P.E. No. 49752

UPDATE TO 8TH EDITION (2023) FBC	6/12/23	RJA
UPDATE TO 7TH EDITION (2020) FBC	01/24/21	RJA
DESCRIPTION	DATE	BY